



Project Name: \_\_\_\_\_ AIA#: \_\_\_\_\_ Model #: \_\_\_\_\_

Location: \_\_\_\_\_ SIS#: \_\_\_\_\_ Item #: \_\_\_\_\_ Quantity: \_\_\_\_\_



# 60 Quart Floor Mixer

## Model

SPC60 - 60 Quart Planetary Mixer

### Complies to the following Canadian requirements:

- NF 454-00
- CSA Z432-04
- CSA, C22.2



### Standard Features

- Powerful custom built 3 HP motor
- Three fixed speeds
- Gear-driven, high torque transmission
- Heat-treated hardened steel alloy gears and shafts
- Permanently lubricated transmission
- Thermal overload protection
- Front-mounted digital controls with 60 minute timer and last batch recall
- Rigid cast iron body
- NSF approved enamel gray paint
- Industry standard #12 attachment hub
- Safety interlocked bowl guard and bowl lift

- Non-slip rubber feet
- 6 foot cord and ground plug

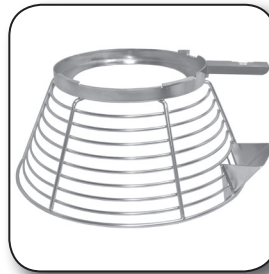

- High-quality stainless steel removable bowl guard with built-in ingredient chute
- Interlocking guard is easy to attach and remove for cleaning
- Dish machine safe

### Standard Accessories:

- 60 quart stainless steel bowl
- Flat beater (aluminum)
- Stainless steel wire whip
- Spiral dough hook (aluminum)
- Bowl truck

### Warranty

- Two-year parts and one-year labor

### Optional:

- Slicer/shredder/grater for #12 hub
- Meat grinder for #12 hub
- Flat beater (stainless steel)
- 30 Qt adapter kit     40 Qt adapter kit

(More options on back)

GLOBE FOOD EQUIPMENT COMPANY

60 Quart Floor Mixer

SPC60



GLOBE FOOD EQUIPMENT COMPANY  
 2153 Dryden Rd., Dayton, OH 45439  
 Phone: 937-299-5493 Fax: 937-299-4147  
 800-347-5423

[www.globeslicers.com](http://www.globeslicers.com)

Approved By: \_\_\_\_\_

Date: \_\_\_\_\_



# 60 Quart Floor Mixer

# SPC60

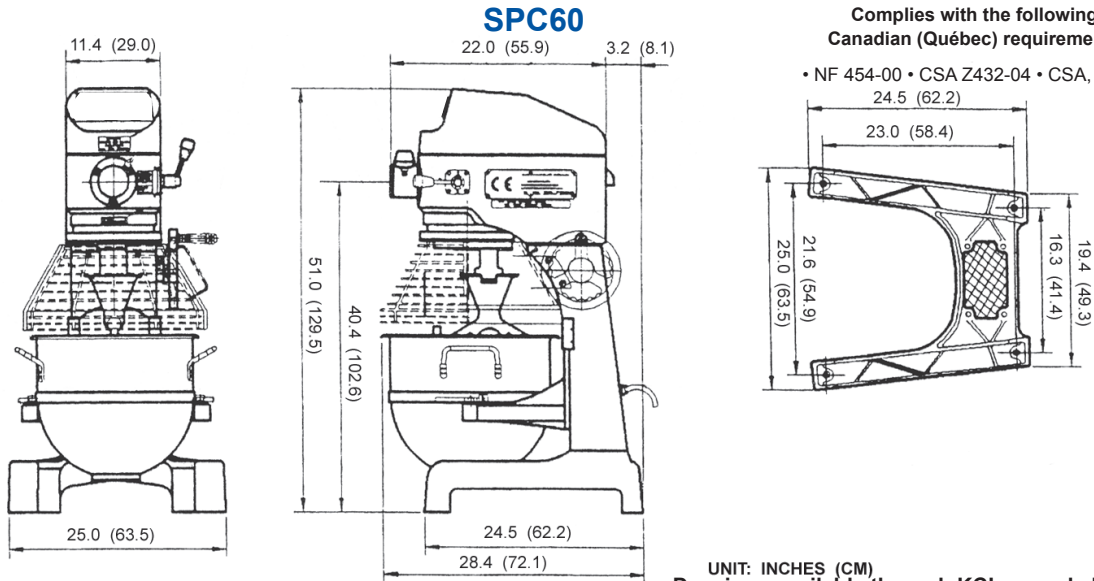

Complies with the following Canadian (Québec) requirements

- NF 454-00 • CSA Z432-04 • CSA, C22.2

UNIT: INCHES (CM)  
Drawings available through KCL. [www.kclcad.com](http://www.kclcad.com)

Model	Elevation	Right	Plan	Back	BIM 3D	Revit
SPC60						

## SPECIFICATIONS

Model	Motor	Volts	Amps	Transmission Type	Capacity	Controls	Agitator Speeds (RPMs)			Attachment Speeds (RPMs)		
							1st	2nd	3rd	1st	2nd	3rd
*SPC60	3 HP	220/60/1 208/60/3	23 9	Gear	64 qt / 60 L	Front-mounted digital controls & timer	62	110	254	52	92	189

**Cord & Plug:** Attached 6 foot flexible 3-wire cord with molded plug fits a grounded receptacle. Single phase NEMA L6-30P Ⓢ Three phase NEMA L15-20P Ⓢ

### STANDARD ACCESSORIES:

- 60 Quart #304 series stainless steel bowl
- Aluminum spiral dough hook and flat beater
- Stainless steel wire whip and bowl guard with built-in ingredient chute
- Bowl truck

- **XXSCRP-60** scraper with mounting kit
- **XXACC30-60** Adapter kit - 30 qt bowl, hook, beater and whip
- **XXACC40-60** Adapter kit - 40 qt bowl, hook, beater and whip
- **XBTRUCK-60** Heavy duty bowl truck

### Chopper Plate Sizes Available:

- **CP02-12** 1/16" (2 mm)
- **CP04-12** 5/32" (4 mm)
- **CP05-12** 3/16" (5 mm)
- **CP06-12** 1/4" (6 mm)
- **CP08-12** 5/16" (8 mm)
- **CP10-12** 3/8" (10 mm)
- **CP12-12** 1/2" (12 mm)
- **CP14-12** 9/16" (14 mm)
- **CP16-12** 5/8" (16 mm)
- **CP18-12** 11/16" (18 mm)
- **CP00-12** Stuffing Plate
- **XST12** 1/2" stuffing tube (sheep)
- **XST34** 3/4" stuffing tube (hog)

- **XMCA-SS** Meat Grinder Assembly (Polished stainless steel cylinder, worm gear, ring, and s/s pan. Includes knife, 3/16" plate, and pusher.)
- **XXCK** Chopper knife for the XMCA-SS
- **XASP** Adjustable slicing plate (for vegetables only)
- **XVSGH** 9" Slicer/Shredder/Grater Housing Only (no plates included-must select from plates listed below)
- **XPH** Plate holder -\*only 1 required

### Shredding Plates:

- **XSP332\*** 3/32" (2.3 mm)
- **XSP316\*** 3/16" (4.7 mm)
- **XSP14\*** 1/4" (6.3 mm)
- **XSP516\*** 5/16" (7.9 mm)
- **XSP12\*** 1/2" (12.7 mm)
- **XGP\*** Grating plate

### FACTORY INSTALLED OPTION:

- **XXCORR-60** Correctional package includes tamper resistant external fasteners.

\*Specify voltage when ordering

### OPTIONAL ATTACHMENTS & ACCESSORIES:

- **XXBOWL-60** Stainless steel bowl
- **XXBEAT-60** Alum. flat beater
- **XXBEAT-60SS** S/S flat beater
- **XXHOOK-60** Alum. dough hook
- **XXWHIP-60** S/S wire whip
- **XXHDWHIP60-4** Heavy-duty 4 mm S/S wire whip
- **XXHDWHIP60-5** Heavy-duty 5 mm S/S wire whip

## DIMENSIONS & SHIPPING INFORMATION

Freight Class **85**

Cartons are reinforced for shipping. The weight and dimensions of this reinforced carton are included below and may vary from shipment to shipment. **This product ships on a pallet.**

Model	Foot Print	Overall Dimensions	Net Weight	Shipping Dimensions	Shipping Weight
SPC60	24.5" D x 25" W (62 cm x 63.5 cm)	28.4" L x 25" W x 51" H (72 cm x 63.5 cm x 129.5 cm)	572 lbs. (260 kg)	48" L x 46" W x 65" H (122 cm x 122 cm x 165 cm)	795 lbs. (360 kg)



**GLOBE FOOD EQUIPMENT COMPANY**

[www.globeslicers.com](http://www.globeslicers.com)

2153 Dryden Rd.  
Dayton, OH 45439  
Phone: 937-299-5493  
Phone: 800-347-5423  
Fax: 937-299-4147